

ASTD-E30 Series

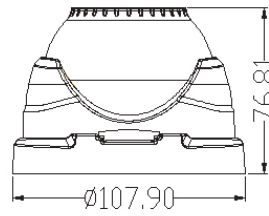
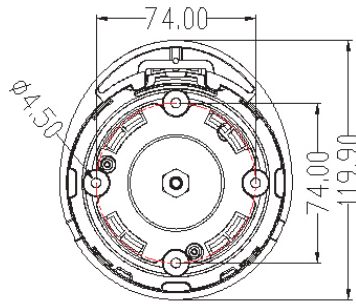

Key Features

- IR Range to 75 ft
- IP 66
- 3D DNR, BLC, VCA
- DC 12V, PoE

ASTD-E30-200E-FX-3.6-DN ASTD-E30-200E-FX-3.6-DN-B	ASTD-E30-200-FX-3.6-DN ASTD-E30-200-FX-3.6-DN-B	ASTD-E30-400-FX-3.6-DN ASTD-E30-400-FX-3.6-DN-B
<ul style="list-style-type: none"> • 2 MP HD Resolution • 3.6 mm Fixed Lens • TDN/True Day Night • White/Black(-B) Housing 	<ul style="list-style-type: none"> • 2 MP HD Resolution • 3.6 mm Fixed Lens • TDN/True Day Night • White/Black(-B) Housing 	<ul style="list-style-type: none"> • 4MP HD Resolution • 3.6 mm Fixed Lens • TDN/True Day Night • White/Black(-B) Housing



SWM10E/SWM10E-B
Wall Mount



SJB10E/SJB10E-B
Junction Box



SPL10
Pole Mount



SCM10
Corner Mount